

# [Press release: Planned roadworks in West Midlands: weekly summary for Monday 23 January to Sunday 29 January 2017](#)

The following summary of planned new and ongoing road improvements over the coming week is correct as of 20 January 2017 but could be subject to change due to weather conditions or unforeseen circumstances. All our improvement work is carried out with the aim of causing as little disruption as possible.

## **A38M – M6 links from out of city A38M: carriageway repairs**

Links from Out of City A38M closed overnight between 9pm and 6am from 23 January until 29 January. A diversion route will be clearly signposted.

## **A449 – Gailey roundabout to Brewood road: carriageway repairs**

Northbound carriageway closed overnight between 8pm and 6am from 23 January until 29 January. A diversion route will be clearly signposted.

## **A46 – Warwick bypass link road southbound: site works**

Southbound carriageway closed overnight between 7pm and 7am from 23 January until 29 January. A diversion route will be clearly signposted.

## **A46 – Warwick bypass link road northbound: site works**

Northbound carriageway closed overnight between 7pm and 7am from 23 January until 29 January. A diversion route will be clearly signposted.

## **A46 – Warwick bypass southbound: site works**

Southbound carriageway closed overnight between 9pm and 6am from 23 January until 29 January. A diversion route will be clearly signposted.

## **A46 – Warwick bypass northbound: site works**

Northbound carriageway closed overnight between 9pm and 6am from 23 January until 29 January. A diversion route will be clearly signposted.

## **A46 – Birmingham Road entry slip road: site works**

Northbound entry slip road closed overnight between 7pm and 7am from 23 January until 29 January. A diversion route will be clearly signposted.

## **A46 – Leek Wootton entry slip road: site works**

Northbound entry slip road closed overnight between 7pm and 7am from 23 January until 29 January. A diversion route will be clearly signposted.

## **A46 – Birmingham Road entry slip road: site works**

Southbound entry slip road closed overnight between 7pm and 7am from 23 January until 29 January. A diversion route will be clearly signposted.

## **A46 – Leamington entry slip road: site works**

Southbound entry slip road closed overnight between 7pm and 7am from 23 January until 29 January. A diversion route will be clearly signposted.

## **A5 – Gledrid roundabout and approaches: widening scheme**

Roundabout and associated approaches closed overnight between 9pm and 6am from 26 January until 29 January. A diversion route will be clearly signposted.

## **A500 – Talke junction island: carriageway works**

Eastside of the Island closed for 24 hours 7 days a week from 9 January ongoing until 31 March. A diversion route will be clearly signposted.

## **M40 – junction 16 to M42 junction 3: carriageway works**

Northbound carriageway closed overnight between 10pm and 6am from 25 January until 28 January. A diversion route will be clearly signposted.

## **M42 – junction 11 entry slip road: carriageway works**

Southbound entry slip road closed overnight for one night from 9pm 23 January until 6am the following morning (24 January). A diversion route will be clearly signposted.

## **M42 – junction 9 to junction 6 including junction 9 entry slip and links to M6: carriageway works**

Southbound carriageway, junction 9 entry slip road and link roads to M6 closed overnight between 10pm and 5.30am from 23 January until 27 January. A diversion route will be clearly signposted.

## **M5 – junction 6 to junction 5 including junction 6 northbound entry slip: major scheme works**

The northbound carriageway will be closed overnight between 8pm and 6am from 23 January until 26 January. A diversion route will be clearly signposted.

## **M5 – junction 5 to junction 4a including junction 5 northbound entry slip: major scheme works**

The northbound carriageway will be closed overnight between 8pm and 6am from 25 January until 27 January and on January 29. A diversion route will be clearly signposted.

## **A45 – Tollbar underpass: carriageway works**

The carriageway will be closed in both directions between 8pm and 6am on January 28 and 29. A diversion route will be clearly signposted. The B4110 London Road will also be closed from 8pm on January 27 until 8pm on January 29.

## **M50 – junction 1 exit slip road: carriageway works**

Eastbound exit slip road closed overnight between 9pm and 6am from 23 January until 25 January. A diversion route will be clearly signposted.

## **M50 – junction 1 entry slip road: carriageway works**

Westbound entry slip road closed overnight between 9pm and 6am from 23 January until 25 January. A diversion route will be clearly signposted.

## **M54 – junction 5 to junction 6: carriageway works**

Eastbound carriageway closed overnight between 8pm and 6am from 23 January until 29 January. A diversion route will be clearly signposted.

## **M54 – junction 5 to junction 7: carriageway works**

Westbound carriageway closed overnight between 8pm and 6am from 23 January until 29 January. A diversion route will be clearly signposted.

## **M54 – junction 5 entry slip road: carriageway works**

Westbound Entry Slip Road closed overnight between 8pm and 6am from 23 January until 29 January. A diversion route will be clearly signposted.

## **M54 – junction 7 to junction 6 including junction 7 entry slip road: carriageway works**

Eastbound carriageway including the entry slip road closed overnight between 10pm and 6am from 25 January until 28 January. A diversion route will be clearly signposted.

## **M6 – junction 6 Salford Circus to M6: carriageway works**

Carriageway closed overnight in both directions between 9pm and 6am from 23 January until 29 January. A diversion route will be clearly signposted.

## **M6 – junction 11 to junction 13 including junction 12 entry slip road: carriageway works**

Southbound carriageway and entry slip road closed overnight between 9pm and 6am from 23 January until 25 January. A diversion route will be clearly signposted.

## **M6 – junction 12 exit slip road: carriageway works**

Southbound exit slip road closed overnight for one night from 10pm 25 January until 5.30am the following morning (26 January). A diversion route will be clearly signposted.

### **General enquiries**

Members of the public should contact the Highways England customer contact centre on 0300 123 5000.

### **Media enquiries**

Journalists should contact the Highways England press office on 0844 693 1448 and use the menu to speak to the most appropriate press officer.

---

# [Press release: Planned roadworks in the East of England: weekly summary for Monday 23 to Sunday 29 January 2017](#)

The following information summarises the work being carried out this coming week. It is correct as of the above date but could be subject to change due to weather conditions or unforeseen circumstances. All our improvement work is carried out with the aim of causing as little disruption as possible.

## **New work**

### **M1: technology repairs**

Highways England will be working to repair and replace faulty power cables for signage technology on the motorway, including overhead sign lighting, on the M1. This will be done using lane and hard shoulder closures while we are working, between 9pm and 5am, from Monday 23 January to Friday 10 March. As part of this work, it will be necessary for slip roads to be closed overnight on some dates. Where slip roads are closed, drivers will be diverted to continue on the M1 to the next junction, exit and return to leave the junction from the opposite direction.

### **A1 Tempsford: slip road repair**

Highways England will be repairing the road surface of the southbound entry slip road of the A1 near Tempsford. They will complete this work overnight between Friday 27 and Saturday 28 January, working between 8pm and 6am. The southbound entry slip road to the A1 will be closed during this time. Drivers wanting to join the A1 at Tempsford entry slip road will be diverted northbound to the Black Cat roundabout, exit and return southbound.

### **A12 Boreham: traffic light repairs**

Highways England will be repairing the traffic lights on the A12 at the junction 19 (Boreham interchange). This will be done using a southbound slip lane closure while we are working, between 8pm and 6am on Thursday 26 and Friday 27 January.

### **A12 Lowestoft: Bascule Bridge works**

We will be carrying out routine maintenance works on the A12 Bascule Bridge at Lowestoft. This will be between Monday 23 January and Monday 20 February, from 8pm to 6am. During the work the A12 will be closed in both directions at the bridge and a diversion will be clearly signposted. Northbound traffic will travel north from the Bloodmore Lane roundabout on the A1117 (Bloodmoor

Road, Elmtree Road, Cotmer Road), right at the T-junction between A1117 Cotmer Road and A146 Bridge Road onto the A146, left onto the A1117 (Bridge Road) and over the Oulton Broad Bridge, carry on the A1117 (Normanston Drive), turning left at the roundabout with the A1144 (Normanston Drive and Millenium Way) and right along A1117 Bentley Drive, to re-join A12 northbound (Yarmouth Road) by turning left at Tesco roundabout toward Great Yarmouth. Southbound traffic will follow the same route in reverse.

A free hourly bus service will be provided for pedestrians wanting to cross the bridge. This will leave from the north side of the bridge at quarter past the hour and from the south side at quarter to the hour.

### **A421 Bedford: bridge repair work**

We are working to repair bridge joints on the westbound A421 as it passes to the south east of Bedford, at Castle Mill. We will complete this work overnight between Monday 23 and Friday 27 January, working between 8pm and 6am. To keep road users at a safe distance from the works, we will close the A421 between the junction with the A4280 St Neots Road and the junction with the A603 Cambridge Road while we are working. Drivers will be diverted to take the A1 southbound to the Sandy roundabout, then take the A603 westbound towards Bedford, and finally re-join the A421 at the Cardington Cross junction.

## **Ongoing work**

### **Various roads: routine inspections and maintenance for street lighting**

Highways England is carrying out a programme of routine inspections of electrical and structural equipment across the region, which is planned for completion in spring 2017. In addition there is a programme of maintenance which includes bulk lamp changes.

Work will include inspecting equipment on:

- the A47 between Kings Lynn and Norwich with traffic management but no full closures
- the A12 at Capel St Mary's with traffic management but no full closures

Work will include maintenance and bulk lamp changes on the A1 between Sandy and Biggleswade with traffic management but no full closures.

### **Various roads: barrier repairs**

Highways England will continue repairs to barriers throughout the week, using lane closures to keep road users at a safe distance from the work. The work will take place at various locations, between 8pm and 5am. This week we are repairing barriers on the M11 in both directions from Monday 23 to Friday 29 January overnight, using lane closures while we are working between junctions 6 (M25) and 9 (A11). We are also repairing barriers on the A120 in both

directions, between junction 8 with the M11 and Braintree (Marks Farm).

### **Various roads: litter picking and sweeping**

Highways England will continue litter picking throughout the week on the M11. This will be done using a mobile slow-moving hard shoulder or lane closure. Work will also include sweeping the hard shoulder of the M11 during the day while we litter pick between junctions 6 (M25) and 9 (A11).

### **M11 and A120: structures maintenance**

Highways England are carrying out routine maintenance work on bridges crossing the M11 between junctions 6 (M25) and 9 (A11) in both directions. They will also be doing similar work on the A120, between junction 8 with the M11 and Braintree (Marks Farm). These will be done during the day, with the hard shoulder closed while we are working.

### **M11 and A120 Stansted Airport: pothole filling**

Highways England will be filling in potholes on the M11 between junctions 8 (Stansted Airport – Bishop's Stortford) and 9 (A11) in both directions, and on the A120 between Braintree and junction 8 of the M11. This will be done using lane and hard shoulder closures while we are working, between 8.30pm and 6am, from Monday 23 to Friday 29 January.

### **M11: routine maintenance**

Highways England will be doing routine maintenance of structures and technology boxes along the M11 during the day. These will be done with a hard shoulder closure, taking place between junctions 6 (M25) and 9 (A11).

### **A5-M1 Link (Dunstable Northern Bypass), Bedfordshire: major improvements**

Highways England is building a new 2.9-mile, two-lane dual carriageway running from north of Dunstable and joining the M1 at a new junction 11a, south of Chalton. Main construction started in March 2015. Work is progressing well. The traffic management, including hard shoulder closures, safety barriers, signs, CCTV and average speed cameras, will stay in place throughout the construction work, which will be carried out in phases and should be finished in spring 2017.

### **Work on the M1**

This week there will be M1 lane closures between junctions 10 and 13 from Monday 23 to Saturday 27 January between 10pm to 6am for overhead gantry works.

There will be overnight M1 road closures between junction 11 and 12 for new sign gantry works as follows:

- Tuesday 24 January, M1 closed southbound from 10pm to 6am

- Wednesday 25 January, M1 closed northbound from 10pm to 6am

## **Alternative route**

### **M1 southbound junction 12 to 11**

The M1 southbound will be closed at junction 12. Diverted traffic to exit at junction 12 and turn right onto the A5120 through Toddington to Houghton Regis, turn left onto High Street and continue to the roundabout with The Green and Park Road north, taking the third exit onto Park Road north to the roundabout with Poynters Road, take the third exit onto Poynters Road and follow to the roundabout with Poynters Rd and A505 Dunstable Road. Take the first exit onto A505 and continue along the A505 to junction 11 of the M1 and re-join southbound M1.

### **M1 northbound junction 11 to 12**

M1 northbound traffic to exit at junction 11 and turn left onto A505 Dunstable Rd, at the roundabout at A505 and Poynters Road take the third exit onto Poynters and continue to the roundabout with Poynters Road and Park Road North, take the second exit and continue on Park Road North to the next roundabout and take the first exit onto The Green. Continue along to the High Street to the roundabout with Bedford Road (A5120), turn right onto Bedford Road and follow the A5120 via Toddington to M1 junction 12 and re-join the M1.

### **Work on the A5 and local roads**

This week there will be traffic lights overnight on the A5-A505 between 8pm and 6am for safety barrier installation and construction of a new footpath works. There will be off-peak temporary traffic lights on local roads and A5 between 9.30am and 3.30pm for verge and safety barrier work.

### **Cycle improvements schemes in Suffolk, Essex, Norfolk and Bedfordshire**

Work is substantially completed on the building or improving of cycle paths at 16 locations across the East of England including on the A12, A120, A47 and A5.

The work included the installation of new and upgraded shared-use foot/cycle ways and toucan crossing facilities. The new or improved paths will make it safer and easier to cycle on or around major A-roads and will improve connections with the local and national cycle network.

The project is part of a country-wide initiative which will see Highways England deliver 200 projects over the next five years after the government set up a £100 million dedicated fund for cycling in its Road Investment Strategy.



## **Ongoing work for this week**

### **A12 Lowestoft – Station Road/Gunton St/Peters Avenue.**

There will be off peak three way lights upgrading the existing footpath works. The northbound bus stop opposite the works has temporarily been suspended, whilst the southbound bus stop has been relocated.

### **A12/A47 renumbering**

On Monday 16 January Highways England started work to renumber part of the A12 to become the A47. This work is being carried out as part of the improvements to the A47/A12 corridor. We will be replacing road signs that currently show the A12 to now show the A47. The work will last approximately 12 weeks to complete. The section of the A12 that currently runs from Lowestoft to Great Yarmouth will become the A47.

There will be off peak lane closures and two/three way traffic lights during the day and night throughout Lowestoft on the A12 installing sign faces and patches.

### **A14 Bury St Edmunds: junction improvements**

Improvement works are being carried out on the A14 junction 45 Rookery Crossroads/Rougham. Works include construction of new eastbound slip roads, which are being funded by Suffolk County Council as part of the Bury St Edmunds Eastern Relief Road scheme. There is a 24 hour 40mph speed limit in place through the works for safety reasons, works are currently taking place overnight using lane closures in both directions. The works are due to take five months to complete.

### **A14 Cambridge to Huntingdon, Cambridgeshire: major improvements**

Early preparatory construction work on the A14 Cambridge to Huntingdon scheme has been underway for a number of months.

We are currently carrying out a variety of tasks which will require us to close lanes/carriageway on the A1, A14 and some of the side roads.

The work we will be doing will include:

- creating strengthened crossing points for site vehicles on a number of the side roads – these are called plant crossings
- installing access points to our construction compounds
- taking core samples of the existing trunk roads to enable appropriate design and construction
- clearing the site of vegetation which is adjacent to the live carriageway
- installing CCTV and average speed cameras

Wherever possible, work will take place at night (usually between 8pm and 6am) to minimise disruption to traffic. During the week commencing 23 January

lane or carriageway closures are planned for the following locations to enable site clearance and installation of CCTV to take place.

All closures will be from 8pm to 6 am unless stated otherwise.

## **Full closures**

Monday 23 to Friday 27 January:

- full closure of the A1 northbound between Brampton Hut and Alconbury
- A1 northbound Brampton Hut entry slip road closed
- A1 northbound Alconbury exit slip road closed

Monday 23 January to Tuesday 24 January:

- full closure of the eastbound A14 between junctions 26 and 31
- eastbound exit towards Cambridge from A14 onto A1307 closed at junction 31 (Girton)

Wednesday 25 to Thursday 26 January:

- full closure of the westbound A14 between junction 31 and junction 26
- westbound exit from A1307 from Cambridge onto A14 closed at junction 31

Friday 27 January:

- full closure of the eastbound A428 between Caxton Gibbet and Girton

Saturday 28 January at 8am to Monday 30 January at 5am:

- full closure of Hilton Road

## **A14 Cambridgeshire: drainage repairs**

Highways England is undertaking investigations and repairs to the drainage system of the A14 between junctions 32 (Girton – M11 interchange) and 35 (Stoke cum Quy). They will be working off the road during the day clearing vegetation and re-profiling drainage ditches. There will be lane closures and slip road closures between 8pm and 6am while we are working overnight, with all works on weekdays only.

This week we are working on the A14 in both directions with the inside lane closed between junctions 34 and 35.

## **A47 Swaffham: resurfacing**

Highways England will be repairing the road surface of the A47 at Swaffham. They will complete this work until Wednesday 25 January, between 8pm and 6am on weeknights only.

To keep road users at safe distance from works, we will close the A47 between the Lynn Road slip roads and Norwich Road Roundabout in both directions. The speed limit will be reduced to 50mph past the works and this will remain in

place during the day.

Traffic light control will also be required on the A1065 Castle Acre Road.

There will be a clearly signed diversion route in place while we are working, whereby drivers heading westbound will exit the A47 at the A11 Thickthorn Interchange and take the A11 south towards Thetford, then, take the A134 north towards King's Lynn, then, take the A1122 west towards Downham Market, then, take the A10 north to re-join the A47 at King's Lynn.

Drivers heading eastbound will follow this diversion in reverse. Access into and out of Swaffham will be maintained via the A1065, Castle Acre Road, Norwich Road and Lynn Road.

### **A47 Dogsthorpe: junction improvements (Peterborough City Council)**

Peterborough City Council is continuing its junction improvement work at the A47/A15 Dogsthorpe junction, Peterborough. The work will involve some overnight full closure and 24/7 lane closures on the A47. For more information, [visit the Peterborough City Council website.](#)

### **A120 and A12 Essex: essential maintenance work**

We are completing essential maintenance work on the A120 and the A12 in Essex, which will be ongoing until May. This work will include resurfacing, safety barrier repairs, and bridge repairs, with work taking place between Braintree and Marks Tey, near Colchester, at Kelvedon, and at Wix. Unless detailed otherwise, work will be taking place between 8pm and 6am.

This week we are resurfacing the road and footpaths and replacing street lights, fencing and road signs on the A120 from Monday 23 to Friday 27 January, the A120 will be closed while we are working from the Marks Tey roundabout to the Ashbury Drive Marks Tey.. Drivers heading westbound diverted to continue south on the A12 to junction 19, take the A130 northbound to Little Waltham, the A131 northbound through Great Notley, then re-join the A120 at Braintree. Drivers heading eastbound will follow this diversion in reverse. We expect this work to be completed by May.

Between Mark Tey to Marks Farm there will also be temporary traffic lights (one set in Coggershall and Marks Tey) to support the resurfacing works.

We are repairing drainage on the A120 Wix bypass, with work expected to be completed by late April. There will be traffic lights in place and a 40mph speed limit while we are working.

We are replacing the central reservation safety barrier on the A120 between junction 29 of the A12 (Crown Interchange) to Hare Green (between the B1029 and the A133). There will be narrow lanes westbound with a 50mph limit in place in both directions 24/7 throughout the works until mid-March. In addition there will be a lane 2 closure eastbound from Monday 23 to Friday 27 January overnight.

## **A120 Great Bromley: road surface repairs**

Highways England will be repairing the road surface of the A120 near Great Bromley. Subject to weather conditions, we plan to complete this work between Wednesday 25 and Saturday 28 January, working between 8pm and 6am on weeknights only.

To keep road users at a safe distance from the works, we will close the A120 westbound between the Harwich Road junction (shortly before the A133 Hare Green Interchange) and the A12/A120 Crown Interchange at Colchester. The westbound carriageway of the A133/A120 link road will also be closed during our works.

There will be a clearly signed diversion route in place while we are working, whereby drivers heading westbound will:

- exit at Horsley Cross Roundabout and take the B1035 south through Tendring
- take the B1033 west towards Weeley
- take the A133 west towards Colchester
- take the A1232 north towards Ipswich to re-join the A120 at the A12 Crown Interchange

Drivers who miss the Tendring diversion will be turned around at the A120/Little Bromley Road and A120/Harwich Road junctions to pick up the strategic diversion route at Horsley Cross roundabout.

## **General enquiries**

Members of the public should contact the Highways England customer contact centre on 0300 123 5000.

## **Media enquiries**

Journalists should contact the Highways England press office on 0844 693 1448 and use the menu to speak to the most appropriate press officer.

---

## **[RAF Apprenticeship Award](#)**

**RAF trainers are celebrating being recognised as one of the top 100 employers of apprentices in Britain.**

The Service, which currently has 2,700 personnel on its programmes, has provided apprenticeships since its creation in 1918 and in 2014 its scheme was graded 'outstanding,' in all areas by the education standards watch dog Ofsted.

Now the RAF has been included on the prestigious Top 100 Apprenticeship Employers list compiled annually by the National Apprenticeship Service.



Group Captain Stephen Dharamraj, Commandant of the Royal Air Force Central Training School, said: "Apprenticeships are an integral part of our training philosophy by which we ensure that our personnel are able to operate at or above that required by their counterparts in industry. This is essential for the Service to succeed wherever it may be called upon to operate."

Editor: Simon Mander

© MOD Crown Copyright 2016

[Let's block ads! \(Why?\)](#)

---

## welters whatsits – innovation by design

The intellectual property contained within this document is the property of welters®



The designs on the clothing worn by the characters can be seen at London

Fabric 2017 at Stamford Bridge Chelsea

welters® whatsits are a versatile selection of geometric shapes manufactured from the finest marble, creating stunning design possibilities for indoor and outdoor furniture arrangements.

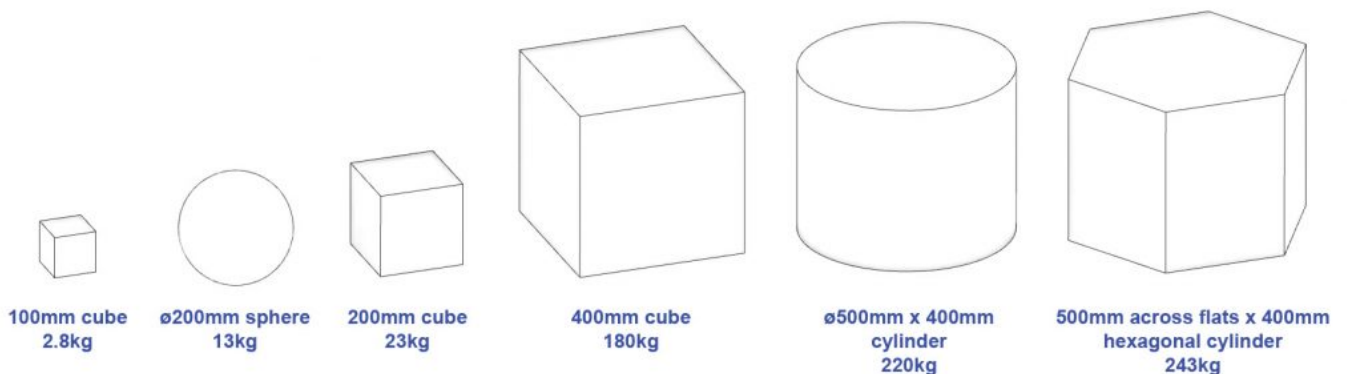

REPRESENTING THE INDUSTRY

# British Furniture Manufacturers

You can see **welters® whatsits** on the **BFM stand** at the **January Furniture Show, NEC Sunday 22 – wed 25 January 2017**

The post [welters whatsits – innovation by design](#) appeared first on [Latest News](#).

---

# Green Party: Government is ignoring climate change warning signs



# Green Party

23 January 2017

The Green Party has responded to the revelation the Government tried to bury its own climate change report [1]. The UK Climate Change Risk Assessment Report warns of significant risk to food supplies, deaths during heatwaves doubling and infrastructure damage due to flooding.

Jonathan Bartley, Green Party co-leader, said:

“It’s astounding the Government appears to have tried to bury its own climate change report. Climate change is the single biggest threat we face. The effects predicted by the report aren’t minor inconveniences – people’s lives are in danger. It’s hugely alarming the Government is sweeping its own warnings under the rug and failing to provide leadership.

“The report was quietly published on January 18, the exact same day experts confirmed 2016 was the hottest year on record [2]. The evidence is overwhelming and the Government should be responding to this report and tackling climate change head on by backing a renewable energy revolution. There is simply no excuse for inaction.”

## Notes:

1.  
<http://www.independent.co.uk/environment/climate-change-risk-assessment-global-warming-government-accused-burying-report-a7540726.html>
2.  
<https://www.greenparty.org.uk/news/2017/01/18/green-party-time-to-stop-breaking-records-and-start-making-change/>

[Tweet](#)

[Back to main news page](#)

Let's block ads! (Why?)